

NOTES

1. MATERIAL: AL AL 6061 T6
2. REMOVE BURRS AND SHARP EDGES.
3. FILLET R0.3 MAX UNLESS OTHERWISE SPECIFIED.
4. FINISH: ANODIC COATING DYED BLACK 12 MICRON.

REVISIONS				
ZONE	REV.	DESCRIPTION	DATE	APPROVED
	A		10/25/2015	

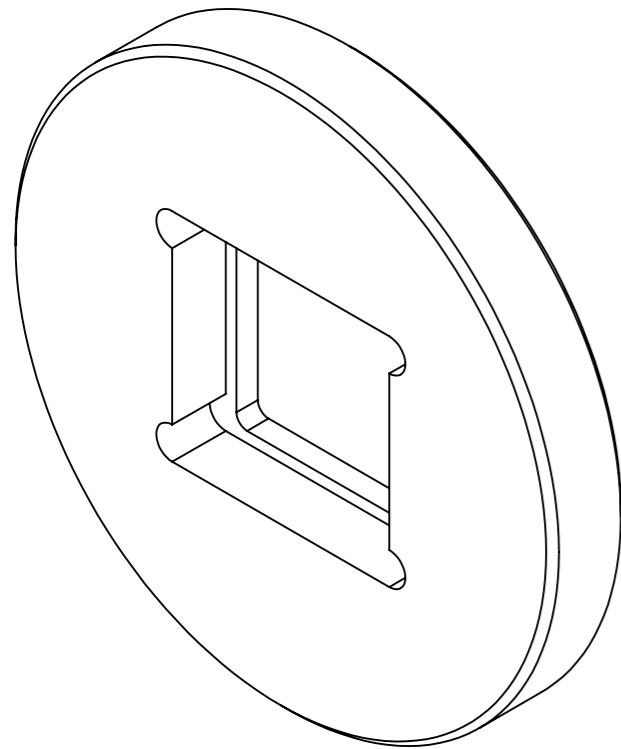
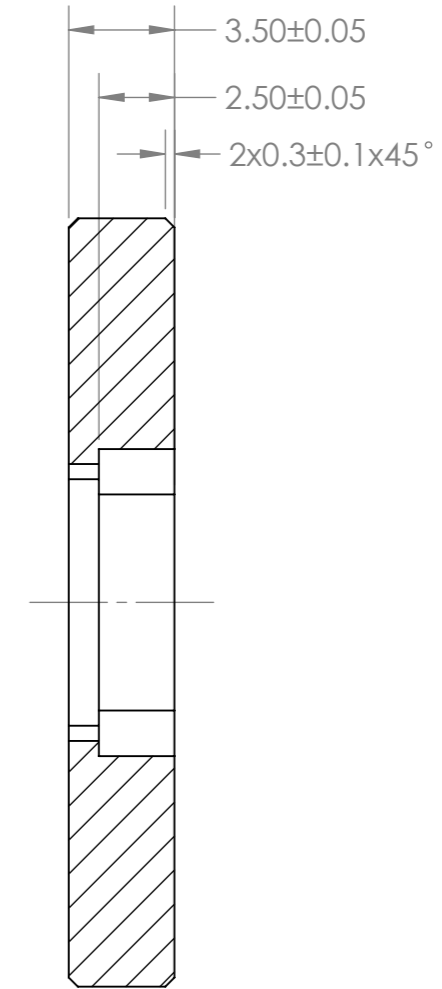
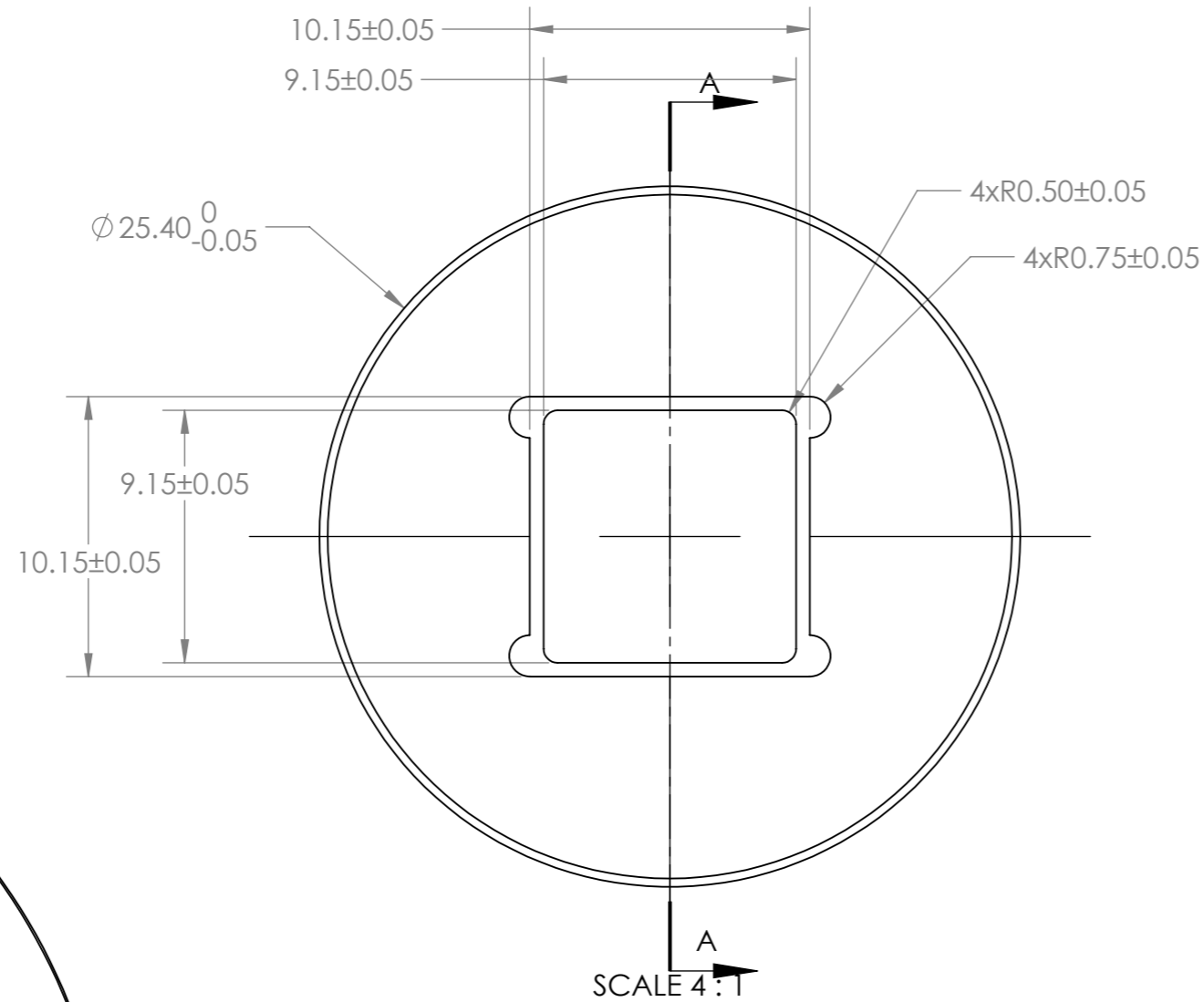

SCALE 4 : 1

SECTION A-A
SCALE 4 : 1

SCALE 4 : 1

UNLESS OTHERWISE SPECIFIED: DIMENSIONS ARE IN MILLIMETERS SURFACE FINISH: TOLERANCES: LINEAR: ± 0.1 ANGULAR: $\pm 0.5^\circ$		FINISH:	DEBUR AND BREAK SHARP EDGES	DO NOT SCALE DRAWING	REVISION	A
DRAWN G.S. 6/12/15 CHK'D L.S. 6/12/15 APPV'D MFG Q.A.				THIS DRAWING IS THE PROPERTY OF HOLO/OR. DUPLICATION OR SUBMISSION TO THIRD PARTIES REQUIRES HOLO/OR'S WRITTEN CONSENT.		
MATERIAL:				TITLE: Adapter for square 10x10mm to 1" dia		
WEIGHT:				DWG/PART NO. AD SQ03 T01		A3
SCALE:10:1				SHEET 1 OF 1		

